

# For Commercial Applications

Job Name \_\_\_\_\_  
 Job Location \_\_\_\_\_  
 Engineer \_\_\_\_\_  
 Approval \_\_\_\_\_  
 Tag \_\_\_\_\_

Contractor \_\_\_\_\_  
 Approval \_\_\_\_\_  
 Contractor's P.O. No. \_\_\_\_\_  
 Representative \_\_\_\_\_

## ISCA-102-D

### Industry Standard Back-To-Back Horizontal 1000 lb. Closet Carrier Specification

Watts ISCA-102-D *Industry Standard* back-to-back horizontal adjustable water closet carrier with epoxy coated cast iron fitting, 4"(102) no hub waste and 2"(51) no hub vent connections, epoxy coated ductile iron patented compression seal face-plate assembly, and epoxy coated ductile iron foot supports with incremental height markings. Adjustable for standard and wheel-chair height, ductile iron rear anchor support, adjustable ABS nipple with integral test cap and neoprene bowl gasket, stainless steel support rods and hardware, and chrome plated cap nuts. Carrier complies with requirements of ASME A112.6.1M up to a 1000 lb. (454 kg.) static load.

| Options (Select One or More) | Suffix                   | Description | □                        |
|------------------------------|--------------------------|-------------|--------------------------|
| -3                           | 3" No Hub Fitting        |             | <input type="checkbox"/> |
| -36                          | 36" Long Barrel Fitting  |             | <input type="checkbox"/> |
| -CI                          | Cast Iron Nipple         |             | <input type="checkbox"/> |
| -HS                          | Hub & Spigot Connections |             | <input type="checkbox"/> |
| -M11                         | Tiling Frame             |             | <input type="checkbox"/> |
| -M20                         | Flush Valve Support      |             | <input type="checkbox"/> |

**Please refer to watts.com for BAA information on specific models.**

**NOTICE**

All foot supports must be securely anchored to concrete floor with min. 1/2"(13) anchors with pull-out force of 500 lbs. (227 kg.).

Dual slotted carrier feet require one 1/2"(13) anchor bolt per foot.

**NOTICE**

The information contained herein is not intended to replace the full product installation and safety information available or the experience of a trained product installer. You are required to thoroughly read all installation instructions and product safety information before beginning the installation of this product.

Watts product specifications in U.S. customary units and metric are approximate and are provided for reference only. For precise measurements, please contact Watts Technical Service. Watts reserves the right to change or modify product design, construction, specifications, or materials without prior notice and without incurring any obligation to make such changes and modifications on Watts products previously or subsequently sold.

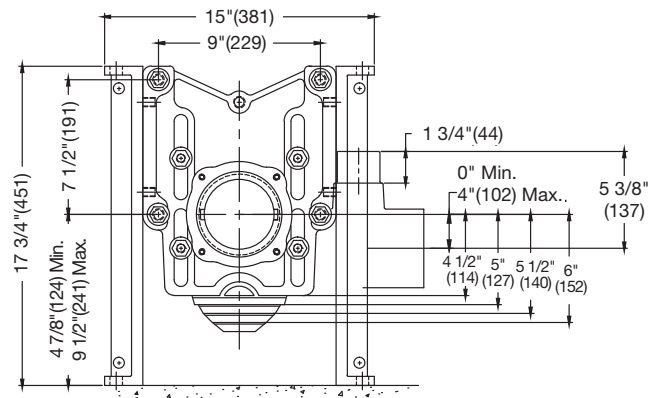
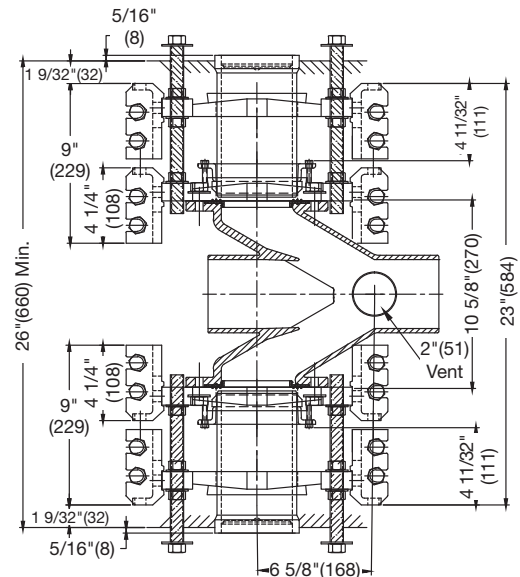

Note: Left hand carrier shown; right hand carrier is mirror image



**USA:** T: (800) 338-2581 • F: (828) 248-3929 • Watts.com  
**Canada:** T: (888) 208-8927 • F: (888) 479-2887 • Watts.ca  
**Latin America:** T: (52) 55-4122-0138 • Watts.com