

Engineering Specification

Job Name _____
 Job Location _____
 Engineer _____
 Approval _____
 Tag _____

Contractor _____
 Approval _____
 Contractor's P.O. No. _____
 Representative _____

SI-750-TO Chrome Plated Hair Interceptor Specification

Watts SI-750-TO chrome plated cast iron hair interceptor with gasketed cover, slip joint inlet elbow, removable stainless steel sediment basket, and IPS threaded connections.

Note: 6 1/2"(165) clearance required below cover to remove basket.



Ordering Information			
Suffix	EDP #	Description	Qty.
SI-750-TO	8145708	Chrome Plated Hair Interceptor	<input type="checkbox"/>

Approvals



NOTICE

The information contained herein is not intended to replace the full product installation and safety information available or the experience of a trained product installer. You are required to thoroughly read all installation instructions and product safety information before beginning the installation of this product.

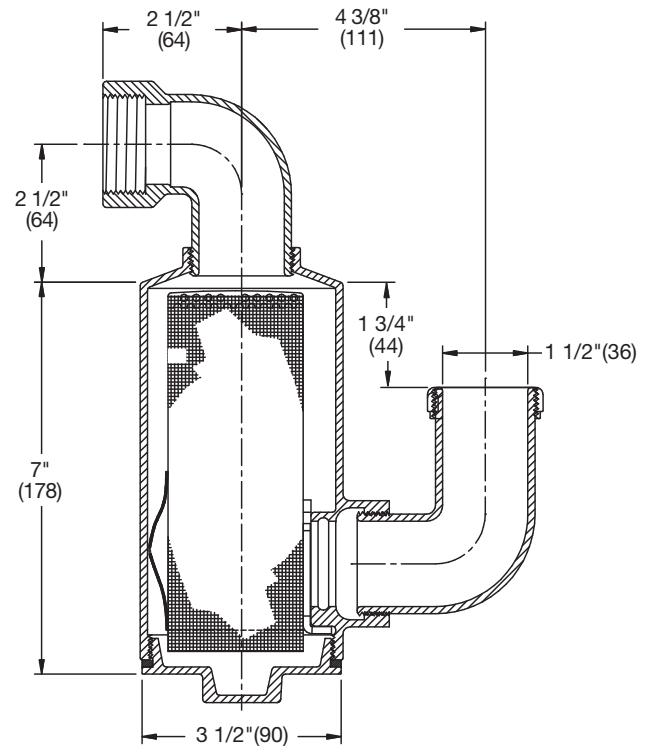

Watts product specifications in U.S. customary units and metric are approximate and are provided for reference only. For precise measurements, please contact Watts Technical Service. Watts reserves the right to change or modify product design, construction, specifications, or materials without prior notice and without incurring any obligation to make such changes and modifications on Watts products previously or subsequently sold.



USA: T: (800) 338-2581 • F: (828) 248-3929 • Watts.com
Canada: T: (888) 208-8927 • F: (888) 479-2887 • Watts.ca
Latin America: T: (52) 55-4122-0138 • Watts.com