

# Engineering Specification

Job Name \_\_\_\_\_

Contractor \_\_\_\_\_

Job Location \_\_\_\_\_

Approval \_\_\_\_\_

Engineer \_\_\_\_\_

Contractor's P.O. No. \_\_\_\_\_

Approval \_\_\_\_\_

Representative \_\_\_\_\_

Tag \_\_\_\_\_

## RD-500 Super Flow Roof Drain Specification

Watts RD-500 epoxy coated cast iron roof drain with flashing clamp with integral gravel guard, self-locking ductile iron dome, and no hub outlet.

Pipe Sizing		
Suffix	Description	
10	10"(254) Pipe Size	<input type="checkbox"/>
12	12"(305) Pipe Size	<input type="checkbox"/>

Options		
Suffix	Description	
-D	Underdeck Clamp	<input type="checkbox"/>
-F	Deck Flange/Adj. Extension	<input type="checkbox"/>
-L	Vandal Proof Dome	<input type="checkbox"/>
-R	2"(51) External Water Dam	<input type="checkbox"/>
-W	2"(51) Internal Water Dam	<input type="checkbox"/>

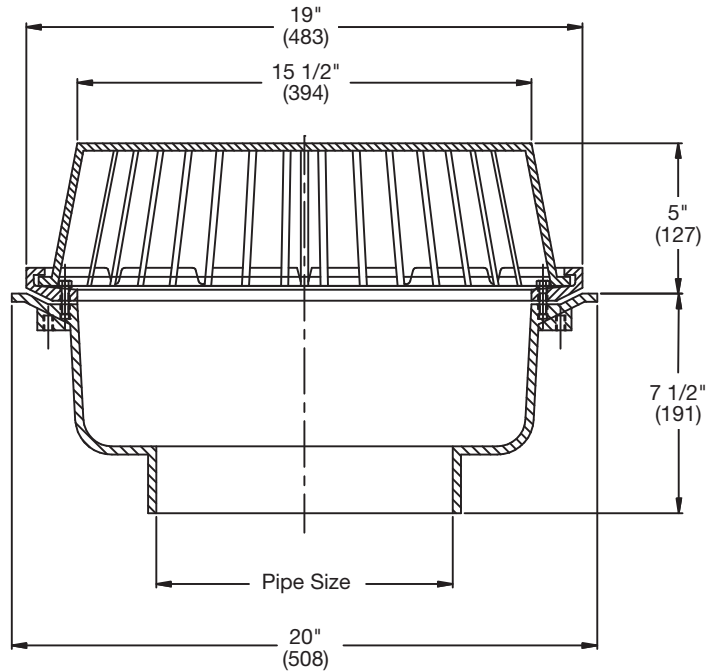

**Deck Opening 18 1/2"(470)  
with Deck Flange 22 3/8"(568)**

Free Area
Sq. In.
275

### NOTICE

The information contained herein is not intended to replace the full product installation and safety information available or the experience of a trained product installer. You are required to thoroughly read all installation instructions and product safety information before beginning the installation of this product.

Watts product specifications in U.S. customary units and metric are approximate and are provided for reference only. For precise measurements, please contact Watts Technical Service. Watts reserves the right to change or modify product design, construction, specifications, or materials without prior notice and without incurring any obligation to make such changes and modifications on Watts products previously or subsequently sold.



**USA:** T: (800) 338-2581 • F: (828) 248-3929 • Watts.com  
**Canada:** T: (888) 208-8927 • F: (905) 481-2316 • Watts.ca  
**Latin America:** T: (52) 55-4122-0138 • Watts.com