

For Commercial Applications

Job Name _____

Contractor _____

Job Location _____

Approval _____

Engineer _____

Contractor's P.O. No. _____

Approval _____

Representative _____

Tag _____

ISCA-550

3-Bolt Service Sink Carrier

Specification

Watts ISCA-550 floor mounted service sink carrier with heavy gauge epoxy coated steel offset uprights with welded feet, epoxy coated cast iron fitting, no hub waste and vent connections (specify size), epoxy coated cast iron patented compression seal faceplate assembly with steel mounting brackets, adjustable ABS nipple with integral test cap and neoprene fixture gasket, plated hardware and chrome cap nuts.

| Options (Select One or More) | |
|------------------------------|--|
| Suffix | Description |
| -3 | 3"(76) NH Waste, 2"(51) NH Vent <input type="checkbox"/> |
| -4-V2 | 4"(102) NH Waste, 2"(51) NH Vent <input type="checkbox"/> |
| -4-V4 | 4"(102) NH Waste, 4"(102) NH Vent <input type="checkbox"/> |
| -CI | Cast Iron Nipple <input type="checkbox"/> |

Please refer to watts.com for BAA information on specific models.

NOTICE

Anchor legs to concrete floor with minimum 1/2"(13) anchor bolts (by others).

NOTICE

The information contained herein is not intended to replace the full product installation and safety information available or the experience of a trained product installer. You are required to thoroughly read all installation instructions and product safety information before beginning the installation of this product.

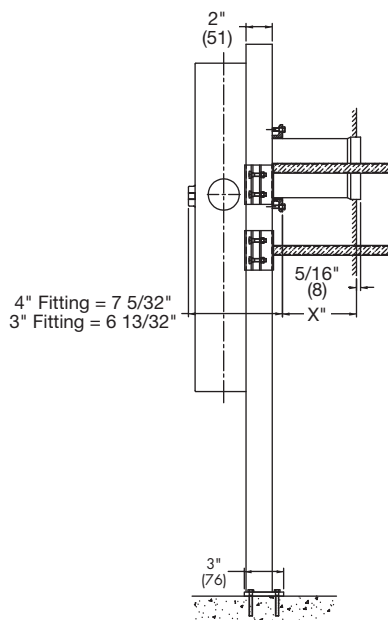
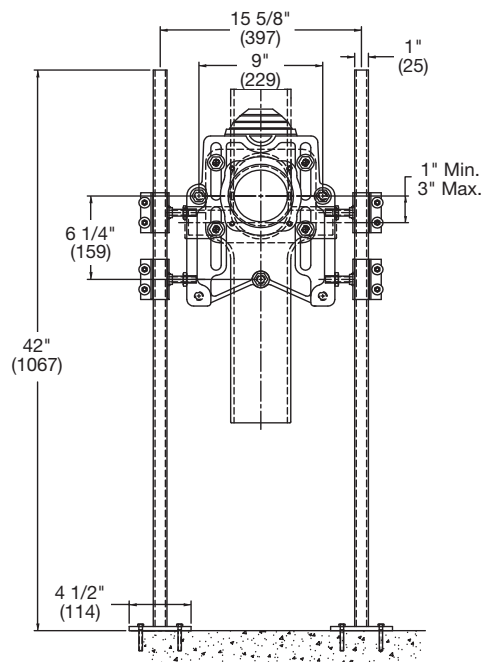

Watts product specifications in U.S. customary units and metric are approximate and are provided for reference only. For precise measurements, please contact Watts Technical Service. Watts reserves the right to change or modify product design, construction, specifications, or materials without prior notice and without incurring any obligation to make such changes and modifications on Watts products previously or subsequently sold.



USA: T: (800) 338-2581 • F: (828) 248-3929 • Watts.com
Canada: T: (888) 208-8927 • F: (888) 479-2887 • Watts.ca
Latin America: T: (52) 55-4122-0138 • Watts.com