

Engineering Specification

Job Name _____ Contractor _____

Job Location _____ Approval _____

Engineer _____ Contractor's P.O. No. _____

Approval _____ Representative _____

QT-141-4 QT QuickTurn™ 4" Thin Wall Vertical Closet Carrier

Specification

Watts QT-141-4 single vertical thin wall water closet carrier with epoxy coated cast iron fitting, 4" no hub waste and 2" or 4" no hub vent connections, epoxy coated cast iron patented faceplate assembly, and epoxy coated cast iron foot supports with incremental height markings. Adjustable for standard and wheelchair height, adjustable ABS nipple with integral test cap and neoprene bowl gasket, plated hardware and chrome cap nuts. Carrier complies with the requirements of ASME A112.6.1M up to a 500 lb. static load.

Call customer service if you need assistance with technical details.

Options		
Suffix	Description	
-V2	2"(51) Vent	<input type="checkbox"/>
-V4	4"(102) Vent	<input type="checkbox"/>
-M1	ABS 24" Extended Nipple	<input type="checkbox"/>
-M23	2"(51) RH Auxiliary Inlet	<input type="checkbox"/>
-M24	2"(51) LH Auxiliary Inlet	<input type="checkbox"/>
-CA-N8-50-QT	8" Cast Iron Nipple	<input type="checkbox"/>
-CA-N24-50-QT	24" Cast Iron Nipple	<input type="checkbox"/>
-THD	Threaded	<input type="checkbox"/>

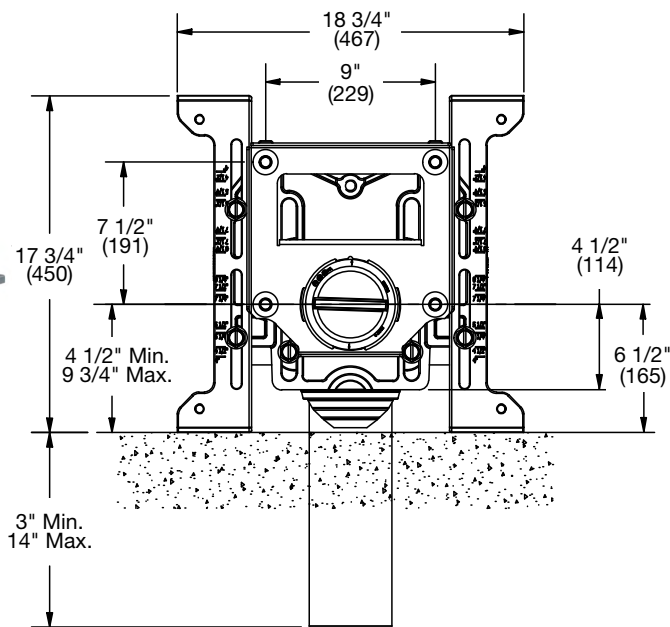
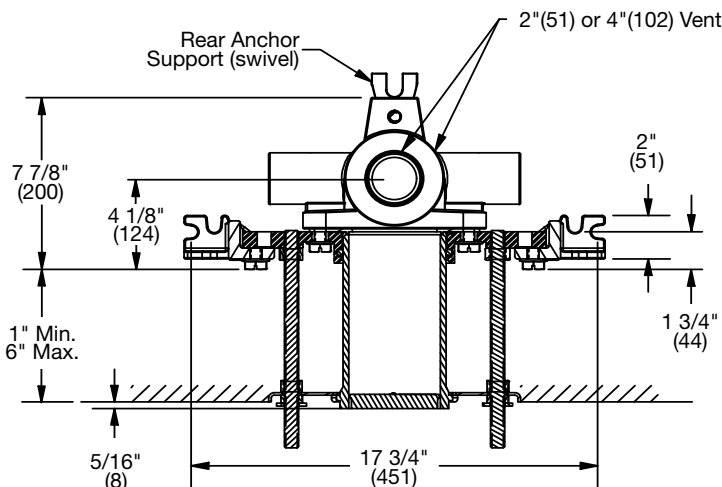

NOTICE

Anchor legs to concrete floor with minimum 1/2"(13) anchor bolts (by others).

Carrier feet require one 1/2"(13) anchor bolt per foot.

NOTICE

The information contained herein is not intended to replace the full product installation and safety information available or the experience of a trained product installer. You are required to thoroughly read all installation instructions and product safety information before beginning the installation of this product.

Watts product specifications in U.S. customary units and metric are approximate and are provided for reference only. For precise measurements, please contact Watts Technical Service. Watts reserves the right to change or modify product design, construction, specifications, or materials without prior notice and without incurring any obligation to make such changes and modifications on Watts products previously or subsequently sold.

