

Engineering Specification

Job Name _____

Contractor _____

Job Location _____

Approval _____

Engineer _____

Contractor's P.O. No. _____

Approval _____

Representative _____

QT-103-D QT QuickTurn™ 750 lb. Back-To-Back Horizontal Adjustable Closet Carrier Specification

Watts QT-103-D back-to-back horizontal adjustable closet carrier with epoxy coated cast iron fitting, 4" no hub waste and 2" no hub vent connections, epoxy coated cast iron patented faceplate assembly, epoxy coated cast iron foot supports with incremental height markings, and rear anchor bar. Adjustable for standard and wheelchair height, adjustable ABS nipple with integral test cap and neoprene bowl gasket, stainless steel support rods and chrome cap nuts. Carrier complies with the requirements of ASME A112.6.1M up to a 750 lb. static load.

Call customer service if you need assistance with technical details.

Options		
Suffix	Description	
-3	3" No Hub Fitting	<input type="checkbox"/>
-36	36" Long Barrel Fitting	<input type="checkbox"/>
QT-100-EXT	Aux. Support System w/ Extended Nipple	<input type="checkbox"/>
-HS	Hub & Spigot Connections	<input type="checkbox"/>
-M1	ABS 24" Extended Nipple	<input type="checkbox"/>
-CA-N8-50-QT	8" Cast Iron Nipple	<input type="checkbox"/>
-CA-N24-50-QT	24" Cast Iron Nipple	<input type="checkbox"/>
-THD	Threaded	<input type="checkbox"/>

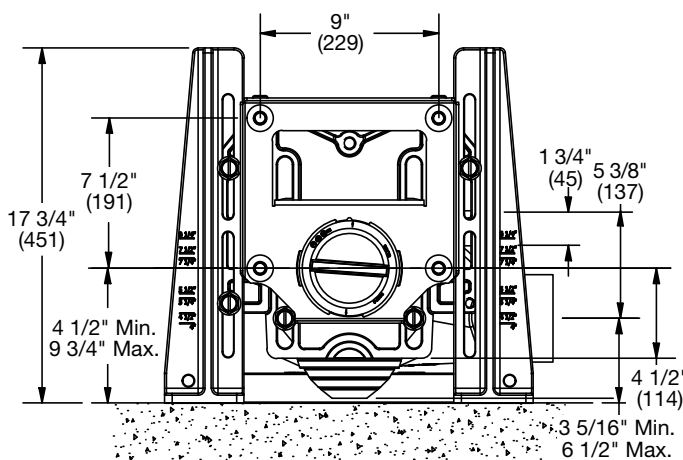
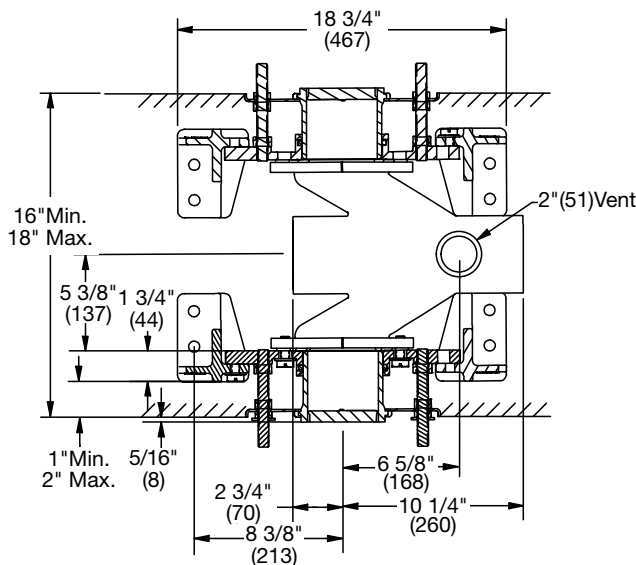

NOTICE

Anchor legs and rear anchor bar to concrete floor with minimum 1/2"(13) anchor bolts (by others).
Carrier feet require two 1/2"(13) anchor bolts per foot.

NOTICE

The information contained herein is not intended to replace the full product installation and safety information available or the experience of a trained product installer. You are required to thoroughly read all installation instructions and product safety information before beginning the installation of this product.

Watts product specifications in U.S. customary units and metric are approximate and are provided for reference only. For precise measurements, please contact Watts Technical Service. Watts reserves the right to change or modify product design, construction, specifications, or materials without prior notice and without incurring any obligation to make such changes and modifications on Watts products previously or subsequently sold.

