

Engineering Specification

Job Name _____

Contractor _____

Job Location _____

Approval _____

Engineer _____

Contractor's P.O. No. _____

Approval _____

Representative _____

QT-101-L/R-BF QT QuickTurn™ Single Horizontal Closet Carrier for Floor Mounted Back Outlet Bowl

Specification

Watts QT-101-L/R-BF single horizontal water closet carrier for floor mounted back outlet bowl with epoxy coated cast iron fitting, 4" no hub waste and 2" no hub vent connections, epoxy coated cast iron patented faceplate assembly, epoxy coated cast iron foot supports with incremental height markings, and adjustable ABS nipple with integral test cap and neoprene bowl gasket, plated hardware and chrome cap nuts.

Call customer service if you need assistance with technical details.

Options		
Suffix	Description	
-3	3" No Hub Fitting	<input type="checkbox"/>
-36	36" Long Barrel Fitting	<input type="checkbox"/>
QT-100-EXT	Aux. Support System w/ Extended Nipple	<input type="checkbox"/>
-HS	Hub & Spigot Connections	<input type="checkbox"/>
-M1	ABS 24" Extended Nipple	<input type="checkbox"/>
-CA-N8-50-QT	8" Cast Iron Nipple	<input type="checkbox"/>
-CA-N24-50-QT	24" Cast Iron Nipple	<input type="checkbox"/>
-THD	Threaded	<input type="checkbox"/>



QT-101-L-R-BF Shown

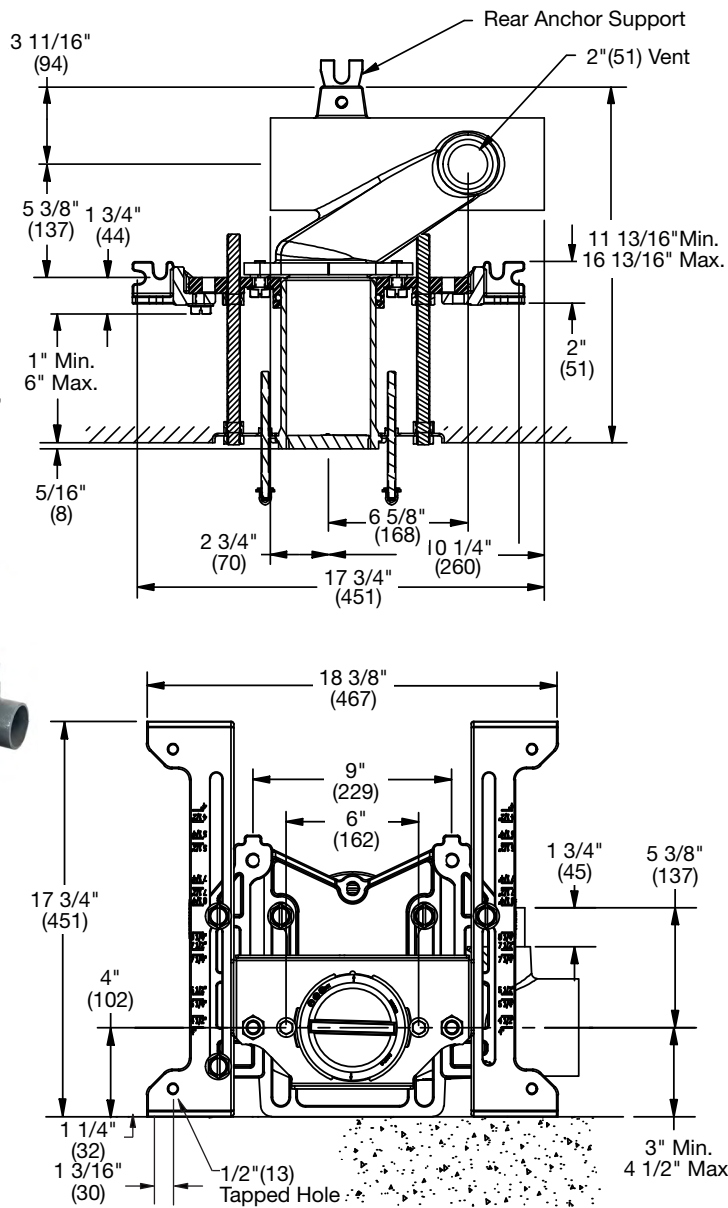

NOTICE

Anchor legs to concrete floor with minimum 1/2"(13) anchor bolts (by others).

Carrier feet require one 1/2"(13) anchor bolt per foot.

NOTICE

The information contained herein is not intended to replace the full product installation and safety information available or the experience of a trained product installer. You are required to thoroughly read all installation instructions and product safety information before beginning the installation of this product.

Watts product specifications in U.S. customary units and metric are approximate and are provided for reference only. For precise measurements, please contact Watts Technical Service. Watts reserves the right to change or modify product design, construction, specifications, or materials without prior notice and without incurring any obligation to make such changes and modifications on Watts products previously or subsequently sold.



USA: T: (800) 338-2581 • Watts.com

Canada: T: (888) 208-8927 • Watts.ca

Latin America: T: (52) 55-4122-0138 • Watts.com

ES-WD-QT-101-L/R-BF 2422

© 2024 Watts

