

Engineering Specification

Job Name _____
 Job Location _____
 Engineer _____
 Approval _____

Contractor _____
 Approval _____
 Contractor's P.O. No. _____
 Representative _____

FD-490-F-80 Aluminum Parking Structure Drain with Heavy Duty Grate and Bucket

Specification

Watts FD-490-F-80 epoxy coated all aluminum parking structure drain with 17" x 17" square anti-ponding top with membrane clamping flange, heavy duty self-closing hinged grate, sediment bucket, and no hub outlet.

Call customer service if you need assistance with technical details.

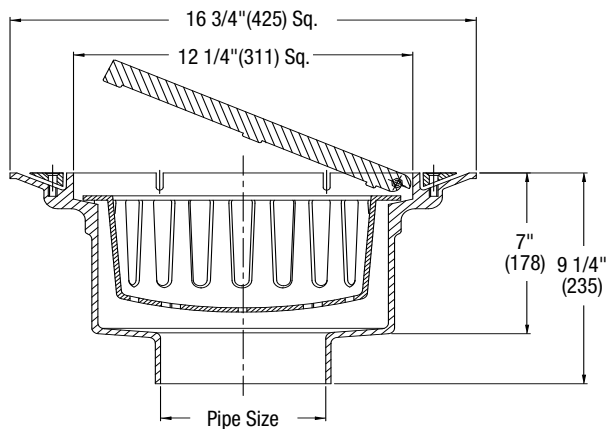

Pipe Sizing		
Suffix	Description	
3	3"(76) Pipe Size	<input type="checkbox"/>
4	4"(102) Pipe Size	<input type="checkbox"/>
6	6"(152) Pipe Size	<input type="checkbox"/>
8	8"(203) Pipe Size	<input type="checkbox"/>

Options		
Suffix	Description	
-6	Vandal Proof	<input type="checkbox"/>

Load Rating	Free Area Sq. In.
XHD	41

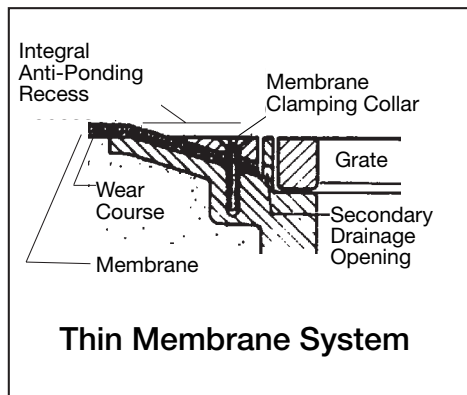

NOTICE

The load classifications are in accordance with the American National Standard ASME A112.21.1M ASME Ratings are as follows:
 XHD Safe Live Load 7500-10,000 lbs. (3375-4500 kg)
 The above categories are given as a guide only. Please consult factory.

NOTICE

The information contained herein is not intended to replace the full product installation and safety information available or the experience of a trained product installer. You are required to thoroughly read all installation instructions and product safety information before beginning the installation of this product.

Watts product specifications in U.S. customary units and metric are approximate and are provided for reference only. For precise measurements, please contact Watts Technical Service. Watts reserves the right to change or modify product design, construction, specifications, or materials without prior notice and without incurring any obligation to make such changes and modifications on Watts products previously or subsequently sold.

