

Engineering Specification

Job Name _____

Contractor _____

Job Location _____

Approval _____

Engineer _____

Contractor's P.O. No. _____

Approval _____

Representative _____

LEAD FREE*

Butterfly Valves Series BF-03-M2 Full Lug and BF-04-M2 Wafer

Sizes: 2" – 12"*** 200psi (13.8 bar)
14" – 24"*** 150psi (10.3 bar)

Watts Series BF resilient seated butterfly valve is available in sizes 2" – 24"*** in wafer or lug body design. Incorporating a 200psi (13.8 bar) pressure rating for 2" – 12"*** and a 150psi (10.3 bar) pressure rating 14" – 24"***, the BF series butterfly is standardly constructed of a ductile iron body with a choice of either ductile iron, aluminum bronze, or 316 stainless steel discs and 416 stainless steel or 316 stainless steel shaft. A phenolic-backed seat (2"-12"**) or aluminum-backed seat (14" – 24"**) prevents the seat from collapsing or dislodging. Standard seat materials available include EPDM, Buna-N and Viton. The BF Series mounting pad is designed to ISO 5211 standard to accommodate lever handles, gear operators, or actuation.

The Watts Series BF butterfly valves are designed and manufactured for use with ANSI 125 or 150 Class flanges and comply with API 609 and MSS-SP 67 standards to meet the stringent requirements of HVAC, Irrigation, OEM, Commercial, Institutional, and Industrial applications.

Approvals

The valves are MSS-SP-67 Type I – Valves for tight shut-off (tested per section 10.2.1). As specified in MSS-SP-67, we conduct 100% shell testing at 1.5 times rated pressure and seat leakage testing at 1.1 times rated pressure.

Features

- **Body** – Available in Full Lug (BF-03-M2) and Wafer (BF-04-M2) styles designed for use between ANSI 125 and 150 flanges. Face-to-face dimensions comply with API 609 and MSS-SP-67. All valves are designed to accommodate 2" of insulation. The mounting pad is designed to ISO 5211 standard. The body material is ASTM A-536 ductile iron.
- **Disc** – Disc edge is machined and polished 360 degrees to assure leak-tight shutoff while minimizing operating torque. Positive, disc-to-shaft connection is provided by stainless steel precision taper pins. Discs are available in ductile iron, aluminum bronze, or 316 stainless steel.
- **Seat** – Phenolic or aluminum backed, non-collapsible, resilient seat is mechanically secured to allow for dead-end service usage to the full pressure rating in lug style valves. Full 360 degrees sealing isolates the body components from the media and provides the primary shaft seal. Seats are available in EPDM, Buna-N, and Viton.



EPDM seat only

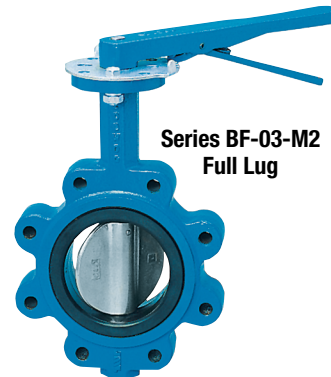

Series BF-03-M2
Full Lug



Series BF-04-M2
Wafer

- **Shaft** – One-piece shaft delivers positive disc-to-seat location with maximum strength. 416SS is standard shaft with ductile iron and aluminum bronze disc. 316SS shaft is standard with 316SS disc models.

Three shaft bushings provide shaft support for proper alignment and minimal shaft deflection. Bi-directional shaft seals prevent external contamination of the stem area and provide backup for the primary shaft seal formed by the disc/seat interface.

- **Handle** – ISO 5211 top work design allows for standard 10 position handle 2" – 6"*** and manual, worm gear operators for 8" – 24"*** sizes. An infinite positioning locking handle is an available option on 2" – 12"*** valves. The posi-lok handle provides an infinite position stop, a memory stop, and a pad-locking device in the fully closed position.

NOTICE

The information contained herein is not intended to replace the full product installation and safety information available or the experience of a trained product installer. You are required to thoroughly read all installation instructions and product safety information before beginning the installation of this product.

NOTICE

Inquire with governing authorities for local installation requirements

*The wetted surface of this product contacted by consumable water contains less than 0.25% of lead by weight.

**This product is produced with ASME/ANSI flanged end connections.

Watts product specifications in U.S. customary units and metric are approximate and are provided for reference only. For precise measurements, please contact Watts Technical Service. Watts reserves the right to change or modify product design, construction, specifications, or materials without prior notice and without incurring any obligation to make such changes and modifications on Watts products previously or subsequently sold.

Dimensions

2" through 24"

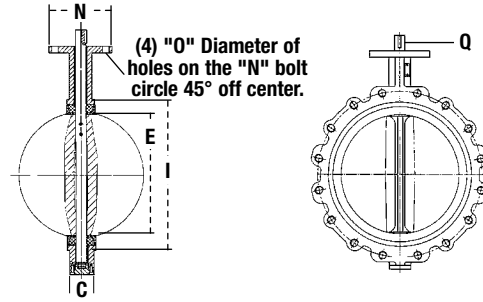
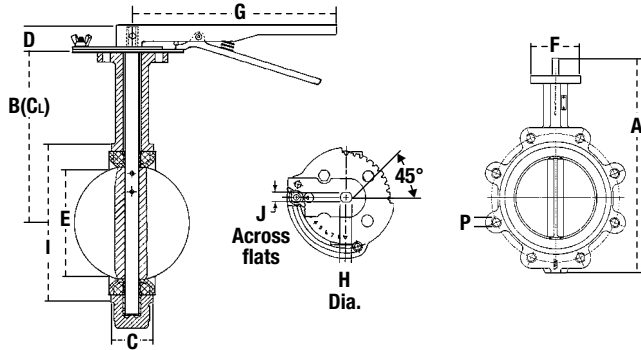

SIZE	DIMENSIONS																			
in.	A	B	C	D	E	F	G	H	I	J										
in.	mm	mm	mm	mm	mm	mm	mm	mm	mm	mm										
2	10 3/4	273	6 3/8	161	1 5/8	42	1 1/4	32	2 1/8	54	3 1/8	77	10 1/2	267	1/2	13	3 3/4	95	3/8	9
2 1/2	11 5/8	295	6 7/8	175	1 3/4	45	1 1/4	32	2 1/2	64	3 3/8	77	10 1/2	267	1/2	13	4 1/4	108	3/8	9
3	12 3/8	308	7 1/8	181	1 3/4	45	1 1/4	32	3 1/8	79	3 3/8	77	10 1/2	267	1/2	13	4 3/4	120	3/8	9
4	13 3/8	346	7 7/8	200	2	52	1 1/4	32	4 1/8	105	3 3/8	92	10 1/2	267	3/4	16	6 1/8	154	7/16	11
5	14 5/8	372	8 3/8	213	2 1/8	56	1 1/4	32	4 1/2	124	3 3/8	92	10 1/2	267	3/4	19	7 1/8	181	1/2	13
6	15 5/8	397	8 7/8	226	2 1/8	56	1 1/4	32	6 1/8	156	3 3/8	92	10 1/2	267	3/4	19	8 3/8	208	1/2	13
8	18 1/8	479	10 1/4	260	2 3/8	60	1 1/4	32	8	202	5	125	14	356	7/8	22	10 1/2	260	5/8	16
10	21 1/4	540	11 1/2	292	2 3/8	66	1 1/4	45	9 1/2	251	5	125	14	356	1 1/8	29	12 1/2	320	1 1/8	21
12	24 5/8	626	13 3/4	337	3	76	1 1/4	45	11 3/8	301	6	150	14	356	1 1/4	32	14 3/4	375	--	--
14	26 3/4	679	14 1/2	368	3	76	1 1/4	45	13 1/8	333	6	150	--	--	1 1/4	32	15 5/8	405	--	--
16	30	762	15 1/4	400	3 3/8	87	2	50	15 3/8	391	6 1/8	175	--	--	1 1/2	33	18 1/2	470	--	--
18	31 1/2	800	16 1/8	422	4 1/8	105	2	50	17 3/8	442	6 1/8	175	--	--	1 1/2	38	20 1/8	525	--	--
20	35 1/8	897	18 1/8	480	5 1/8	130	2 1/8	53	19 3/8	493	8 1/4	210	--	--	1 3/4	41	22 1/4	565	--	--
24	42 1/8	1088	22 1/2	562	6	152	2 1/4	58	23 3/8	594	8 1/4	210	--	--	2	50	27 3/8	693	--	--

SEATING TORQUE BUNA-N, EPDM		
SIZE	NORMAL CONDITIONS	
in.	Wet in.-lbs.	Dry in.-lbs.
2	134	214
2 1/2	190	289
3	250	387
4	390	644
5	600	959
6	907	1,542
8	1,697	2,919
10	2,500	4,857
12	3,300	7,071
14	3,500	7,305
16	5,500	10,027
18	8,200	13,437
20	10,000	17,925
24	18,680	28,020

GEAR DIMENSIONS: STD. WEATHERPROOF W/ HANDWHEEL									
VALVE SIZE	CL					CL		TURNS	
	DEPTH	WIDTH	HW	DIA.	HEIGHT	MT PAD	OPEN	CLOSE	UNIT
in.	A	B	C	D	E	F			lbs.
2, 2 1/2, 3	5.0	4.2	6.5	6.0	2.7	1.5	7.0	10.0	
4	5.0	4.2	6.5	6.0	2.7	1.5	7.0	10.0	
5, 6	5.0	4.2	6.5	6.0	2.7	1.5	7.0	10.0	
8	7.0	6.2	9.5	12.0	3.0	1.8	7.5	27.5	
10	7.0	6.2	9.5	12.0	3.0	1.8	7.5	27.5	
12, 14	7.8	6.4	9.5	12.0	3.0	2.0	12.5	33.0	
16	11.5	9.6	15.0	16.0	4.2	2.5	20.0	70.5	
18	11.5	9.6	15.0	16.0	4.2	2.5	20.0	70.5	
20	11.5	9.6	15.0	16.0	4.2	2.5	20.0	70.5	
24	12.6	9.1	15.0	24.0	4.5	2.0	20.0	80.0	

SIZE	TOP PLATE DRILLING		TAPPED LUG DATA		KEY WAY		WEIGHT LBS. †		C _v RATING (Full Open)					
	N	O	BOLT CIRCLE	NO. HOLES	BOLT P	Q	88	87	Size	C _v Rating				
in.	in.	mm	in.	mm	in.	mm			in.	C _v				
2	5/8	7/8	4 1/4	121	4	3/8"-11UNC x 1 1/2"	--	--	8	6	2	135		
2 1/2	5/8	7/8	5 1/2	140	4	3/8"-11UNC x 1 1/2"	--	--	10	7	2 1/2	220		
3	5/8	7/8	6	150	4	3/8"-11UNC x 1 1/2"	--	--	10	7	3	302		
4	3/4	7/8	7 1/2	191	8	3/8"-11UNC x 2"	--	--	17	12	4	600		
5	3/4	7/8	8 1/2	216	8	3/4"-10UNC x 2 1/2"	--	--	25	16	5	1,022		
6	3/4	7/8	9 1/2	241	8	3/4"-10UNC x 2 1/2"	--	--	27	20	6	1,579		
8	4	102	1 1/2	113	298	8	3/4"-10UNC x 2 1/2"	--	--	40	29	8	3,136	
10	4	102	1 1/2	141	362	12	3/8"-9UNC x 2 1/2"	--	--	63	48	10	5,340	
12	5	125	1 1/2	17	432	12	7/8"-9UNC x 3"	1/4 x 1 1/4	6 x 32	107	78	12	8,250	
14	5	125	1 1/2	18 3/4	476	12	1"-8UNC x 3"	1/4 x 1 1/4	6 x 32	156	99	14	11,917	
16	5 1/2	140	1 1/2	18	21 1/4	540	16	1"-8UNC x 3 3/8"	3/16 x 1 1/2	8x46	203	140	16	16,388
18	5 1/2	140	1 1/2	18	22 3/4	578	16	1 1/8"-7UNC x 4 1/2"	3/8 x 1 1/2	10x40	269	188	18	21,705
20	5 1/2	165	1 1/2	22	25	635	20	1 1/8"-7UNC x 5 1/2"	3/8 x 1 1/2	10x40	392	248	20	27,908
24	5 1/2	165	1 1/2	22	29 1/2	750	20	1 1/4"-7UNC x 6"	1/2 x 2 3/8	13x60	593	450	24	43,116

†Weights are for valves with ductile iron or aluminum bronze discs. 2" - 12" have levers; 14" - 24" have bare shafts. Refer to Watts F-CDBF for gear operator weights.

How to Order Watts Series BF-M2

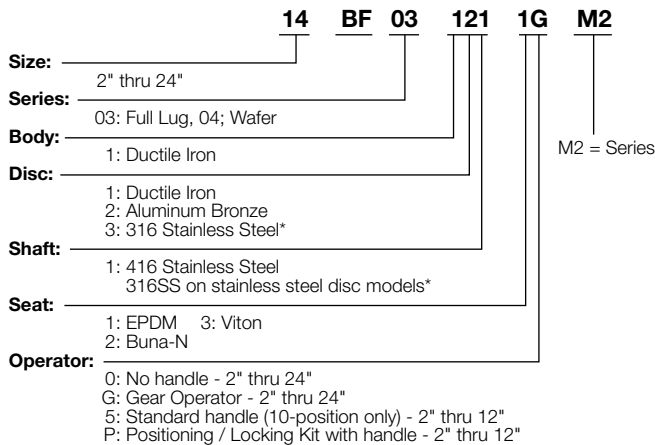

Materials

- Body: ASTM A-536 Ductile Iron epoxy electrostatic sprayed (RAL5015F-NSF).
- Bushing: Duralon(3); Teflon® - Dacron inner liner bonded to fiberglass - epoxy resin outer shell 2"-12"***, Bronze 14"-24"***
- Stem O-rings: Buna-N
- Disc: ASTM A-395 Ductile Iron / Electroless Nickel Plated
ASTM B-148 Aluminum Bronze
ASTM A-351 316 Stainless Steel
- Shaft: 416 Stainless Steel
316 Stainless Steel on 316SS Disc Models
- Seat: EPDM: +5°F to 248°F (-15°C to +120°C)
Buna-N: +14°F to 176°F (-10°C to +80°C)
Viton: -4°F to 302°F (-20°C to +150°C)

NOTICE

Do not use EPDM when hydrocarbons are present.

